

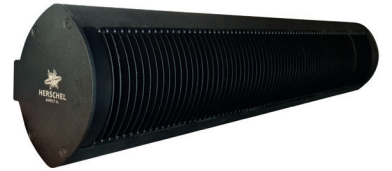

PART NO.	RATED POWER	VOLTAGE	CURRENT	FUSE/CIRCUIT BREAKER RATING	HEATED ZONE	
					Indoor	Outdoor
IRXL2-1300B	1.3kW (2x 650 W) Two black glazed ceramic elements	230V	5.7A	10A	6-9m ²	3-6m ²
IRXL3-1950B	1.95kW (3x 650 W) Three black glazed ceramic elements	230V	8.5A	16A	9-12m ²	4.5-9m ²



FEATURES AND BENEFITS

The Aspect XL is an energy-efficient, space heating solution for indoor spaces and covered, sheltered outdoor use. It is particularly suited for those applications where an aesthetically pleasing, discreet comfort heating solution with zero light is preferred. Office reception areas, shops, hotels, churches, restaurants, public halls, covered patios or terraces and anywhere within the public eye.

Utilising specially developed ceramic emitters in a high quality extruded and anodised aluminium body. The groundbreaking design of the Aspect XL including triple reflectors projects far infrared heat forwards. The result is high efficiency, a wide spread and throw and increased comfort levels, all in a very compact unit. Zero light and featuring a sleek black body and grill, Aspect XL performs as good as it looks.

Other features include:

- No maintenance
- Long lifetime – solid state technology
- Stylish looks and cutting edge design with discreet, black aluminium grill as standard
- Manufactured in Europe to very high quality and European safety standards

For larger commercial projects we would always recommend Herschel carry out a survey or detailed desktop assessment.

2/3 Ceramic LFFE Ceramic Elements

Frame: Black powder coated extruded aluminium

XL2 Heater size
550 x 95 x 138mm -3.4kg

XL3 Heater size
800 x 95 x 138mm - 4.4kg

Aluminised steel reflectors

Heating Up Time < 5 Minutes

Useful Wavelength Range 2-10 µm

IP Rating: IPX4

DIAGRAM 1

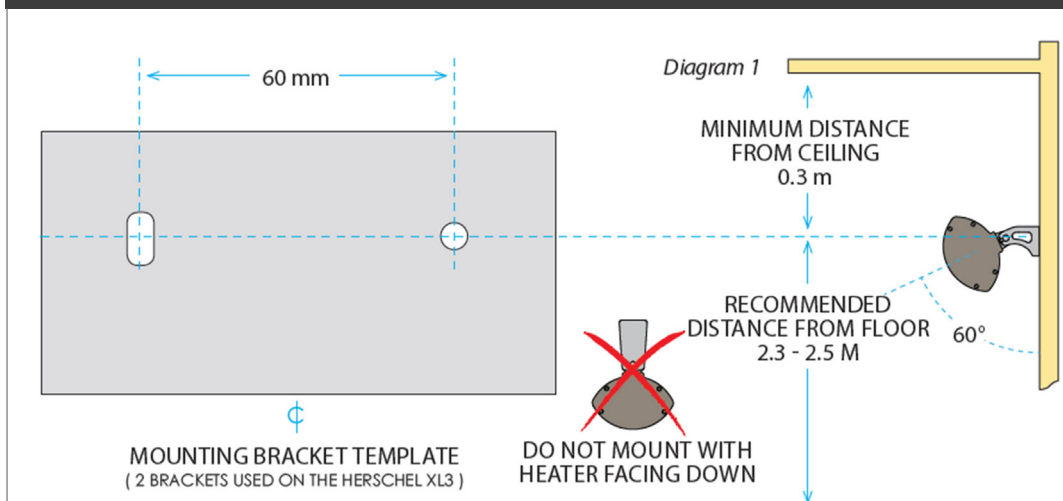

XL2

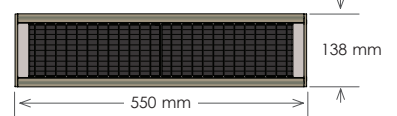

XL3

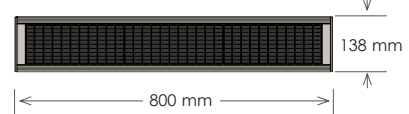

IMPORTANT

In exposed areas with air movement/wind, the far infrared spread may reduce by 1/3 to 1/2. In such areas, or for use in low air temperatures, we would recommend choosing a heater from our middlewave Sunset range or proportionally increasing the number of ASPECT heaters and mounting at the lowest height. Heated zones are based on recommended mounted heights. Please refer to the Herschel ASPECT Installation Manual before installation and for guidance on heated zones and heat intensity at alternative mounting heights.

The unit is protected against water ingress (protection level IPX4), however when used outside it must be installed in a covered outdoor area to give maximum protection and longevity against the effects of driving rain, wind, frost, salt and water contaminations, etc. The canopy/roof/cover must be of a permanent nature, there must be a minimum clearance of 0.3m (12") between the cover and any part of the Herschel Aspect XL and the cover must extend a minimum of 2m (79") from the wall.

The Herschel Aspect XL rises to very high temperatures in use and the unit (in particular the heater elements) must not be touched when power is applied. After switch off the elements remain hot for a considerable time and the unit should not be touched for a minimum of 30 minutes. NEVER use the heater to ignite materials.

The Herschel Aspect XL is guaranteed against failure due to faulty materials or workmanship for five years from the date of purchase and the ceramic elements are warranted for 12 months. In the unlikely event of failure of the unit within this time, the unit must be returned to the supplier for repair or replacement. Refer to the warranty policy on Herschel-infrared.com for more detail including exclusions. The guarantee is invalid if the correct installation instructions have not been adhered to.

